

TMAA03-32 Hand-Held Control Head Remote Interface Kit Installation Instructions



Introduction

The TMAA03-32 is an installation kit for remotely mounting the TMAC70 hand-held control head. The TMAA03-32 provides the following items:

- Six meter remote cable
- Ignition sense cable
- Combining cable
- TMAA03-29 remote interface box.

The installation parts in the following diagram are also available as stand-alone products. The product codes of these parts are shown in brackets ().

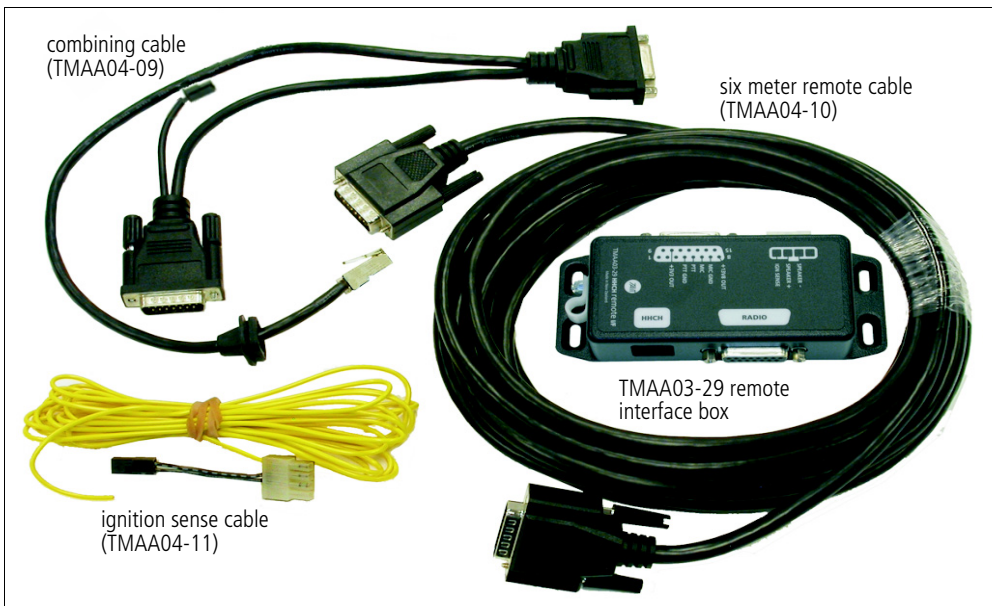

The TMAA03-29 remote interface box allows the following products to be connected to a remotely-installed radio:

- TMAC70 hand-held control head
- Remote speaker TMAA10-03 (for 25W radios) or TMAA10-06 (for 40/50W radios)
- TMAA10-09 remote microphone and footswitch PTT (optional)
- TMAA10-10 remote microphone and gear-lever PTT (optional).

Note: The TMAA10-04 remote PTT and TMAA10-05 hands-free cannot be used with this kit.

Installation Precautions



Warning!! Mount these products securely in a vehicle. Unsecured radio equipment is dangerous to the vehicle occupants.



Important: When drilling holes in a vehicle, check that drilling at the selected points will not damage existing wiring, petrol tanks, fuel lines, brake pipes or battery cables.



Important: This equipment contains devices that are susceptible to static charges. The procedures outlined in this installation guide should therefore be carried out in a static-safe environment. You can obtain information on antistatic precautions and the dangers of electrostatic discharge (ESD) from standards such as ESD S4.1-1997 (revised) or BS EN 100015-4 1994. The Electrostatic Discharge Association website is <http://www.esda.org/>.

Installation

The circled numbers in the “Installation” section refer to the items in the following diagram. The items named in **bold** are part of the TMAA03-32 kit.

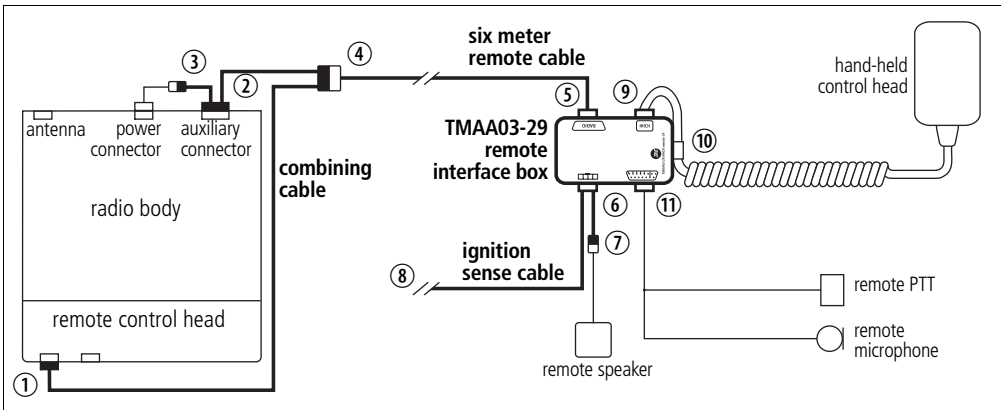

1 Install the radio.

Use a TMAC34-0T (TM8200 radios) or TMAC34-1T (TM9100 radios) remote dual-RJ45 control head, and the appropriate mounting bracket.

Refer to the relevant sections in the service manual or the installation instructions provided with the remoting kit or mounting bracket.

2 Install the **TMAA03-29** remote interface box in the required position.

Note: It may be advisable to install the hand-held control head **before** securing the remote interface box in its final position. Refer to step 7.

3 Install the combining cable.

- Connect the RJ45 plug ① to either of the RJ45 sockets on the remote control head.
- Connect the 15-way plug ② to the radio's auxiliary connector.

- c Release the locking mechanism on the existing remote speaker socket housing and disconnect the remote speaker flying lead.
- d Connect the remote speaker flying lead to the matching socket housing on the combining cable ③.
- e Connect the remaining 15-way socket ④ to the six meter remote cable.

4 Install the six meter remote cable.

- a Drill any holes required for the cable and install suitable grommets or bushings in the holes.
- b Run the remote cable to the remote interface box and plug it into the 15-way socket marked **RADIO** ⑤.

5 Install the remote speaker.

- a Mount the remote speaker in the required position.
For detailed mounting instructions, refer to the relevant sections in the service manual or the installation instructions provided with the remote speaker kit.
- b Insert the remote speaker receptacles into the ignition sense connector socket.

6 Install the ignition sense cable.

- a Plug the ignition sense connector into the remote interface box, in the position marked **SPEAKER - SPEAKER + IGN SENSE** ⑥.
- b If ignition sensing is required, connect the ignition sense cable ⑧ to the 13.8V signal controlled by the vehicle's ignition key. Refer to the relevant sections in the installation guide or service manual for detailed programming and hardware-configuration instructions.
- c Plug the flying lead on the ignition sense connector into the socket housing on the remote speaker cable ⑦.

7 Install the TMA03-32 hand-held control head.

For detailed instructions on how to install the grommet and mounting clip, and for operation and programming, refer to the relevant sections in the service manual. These instructions are also provided with the hand-held control head.

- a Plug the hand-held control head into the remote interface box, in the position marked **HHCH** ⑨ and install the grommet.
- b Unscrew the P-clip ⑩ on the remote interface box, using a 5.5mm hex socket.
- c Clamp the P-clip around the hand-held control head cord and secure in place with the hex nut, so that the hand-held control head cord is held firmly in position.



8 Install a remote microphone and PTT (optional).

- a Mount the remote microphone and PTT in the required position.
For detailed mounting instructions, refer to the relevant sections in the service manual or the installation instructions provided with the TMAA10-09 or TMAA10-10 kits.
- b Plug the TMAA10-09 or TMAA10-10 auxiliary connector into the remote interface box, in the position marked ⑪.

More Information

Refer to your radio provider for more information about this product.